

8 7 6 5 4 3 2 1

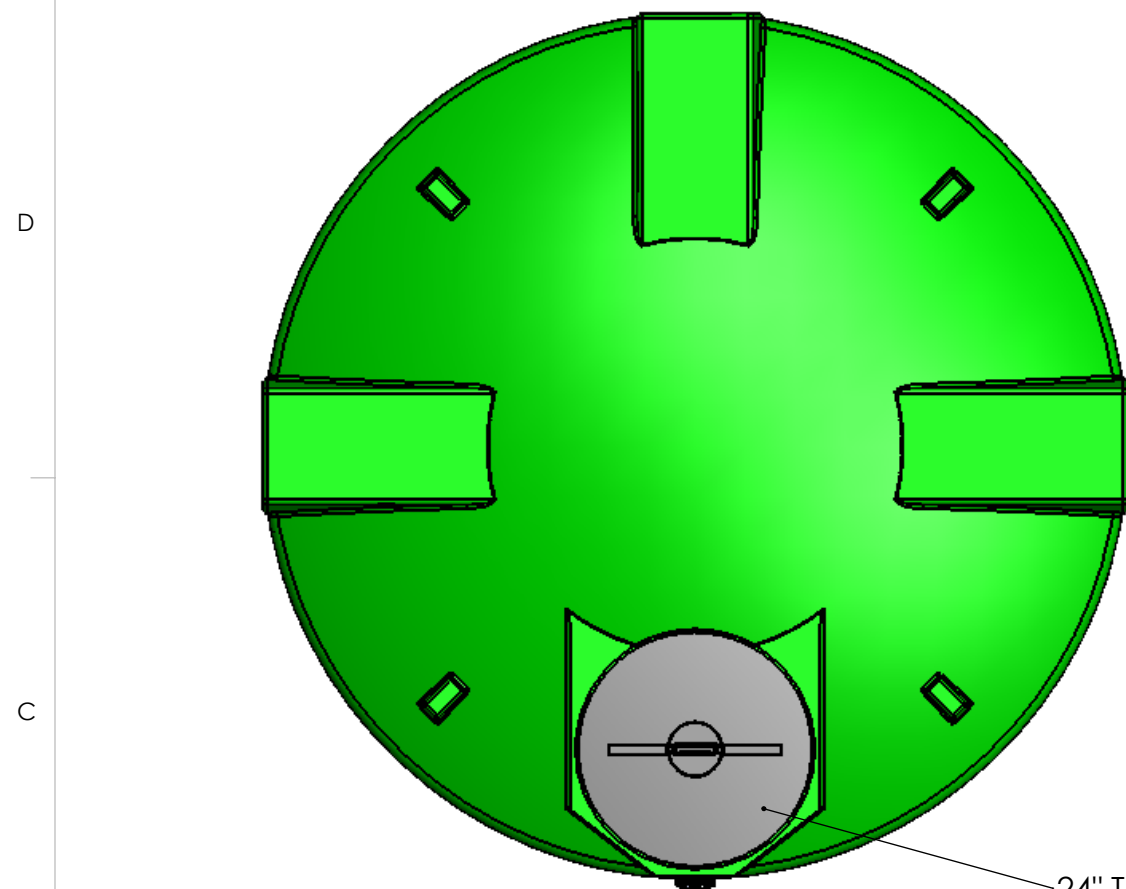

24" THREADED LID
W/BREATHER

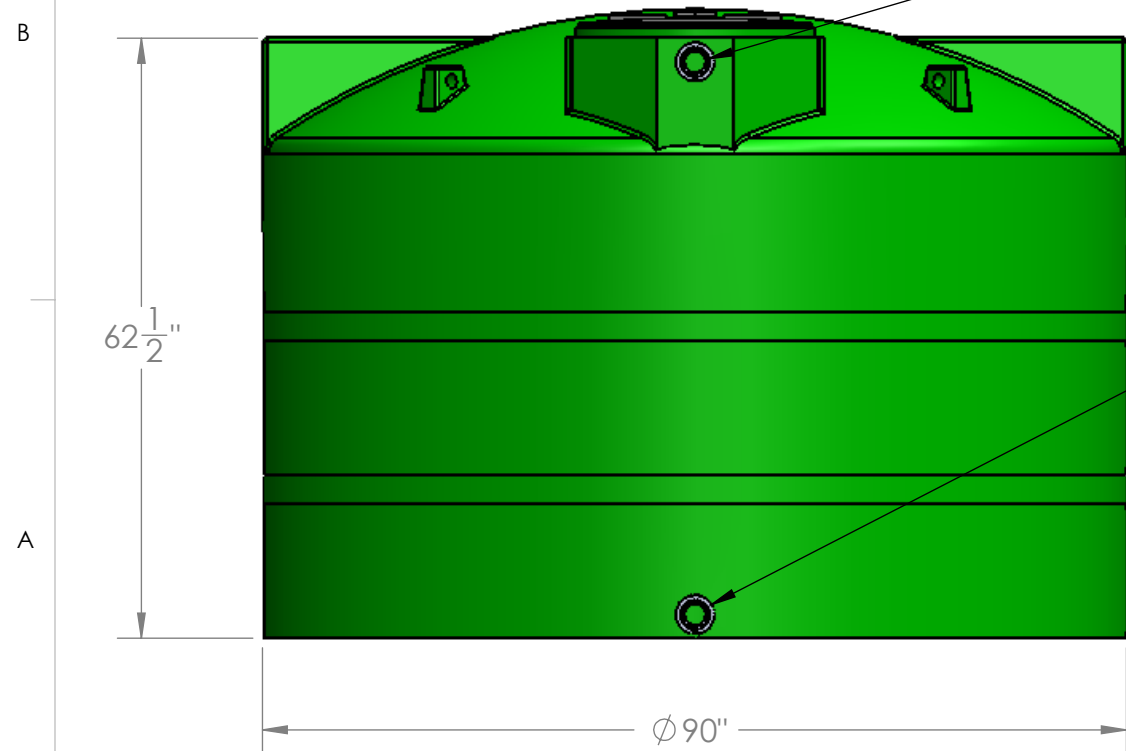
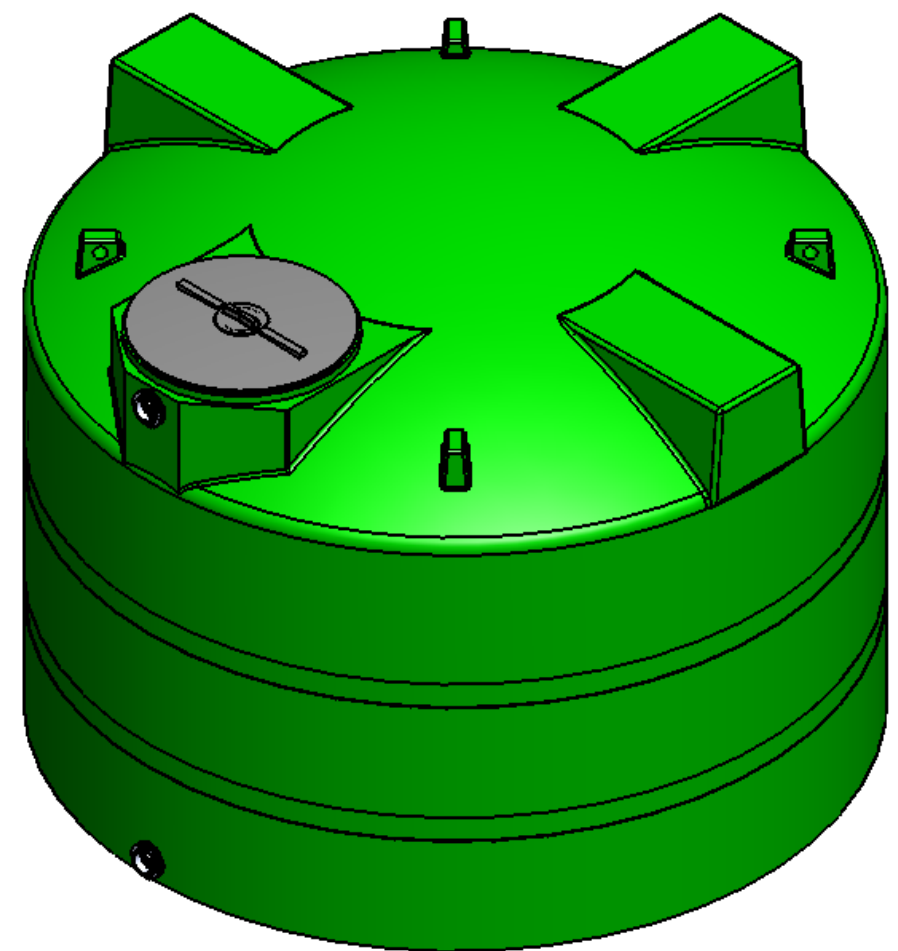

2" NPT
POLYPRO FITTING

2" NPT
POLYPRO FITTING

62 1/2"

Ø 90"

NOTES:

1. MATERIAL: HDPE
2. COLOR: DARK GREEN
3. WEIGHT: 180 LBS.

PROPRIETARY AND CONFIDENTIAL
THE INFORMATION CONTAINED IN THIS DRAWING IS THE SOLE PROPERTY OF <INSERT COMPANY NAME HERE>. ANY REPRODUCTION IN PART OR AS A WHOLE WITHOUT THE WRITTEN PERMISSION OF <INSERT COMPANY NAME HERE> IS PROHIBITED.

		UNLESS OTHERWISE SPECIFIED:		NAME	DATE	 877-468-2657
		DIMENSIONS ARE IN INCHES TOLERANCES: FRACTIONAL ± ANGULAR: MACH ± BEND ± TWO PLACE DECIMAL ± THREE PLACE DECIMAL ±		DRAWN	EBW	
		INTERPRET GEOMETRIC TOLERANCING PER:		CHECKED		TITLE:
		MATERIAL		ENG APPR.		1600 GALLON VERTICAL TANK, FRESH WATER GREEN
		FINISH		MFG APPR.		SIZE
NEXT ASSY	USED ON	DO NOT SCALE DRAWING		Q.A.		DWG. NO.
APPLICATION				COMMENTS:		REV
						B 1600 VT FWG
						SCALE: 1:50 WEIGHT:
						SHEET 1 OF 1

8 7 6 5 4 3 2 1